

## CQDM12/15-810

### 1.2/1.5 Ton Counterbalanced Reach Stacker

Lifting Height: 1400-4500mm

#### Load Curve

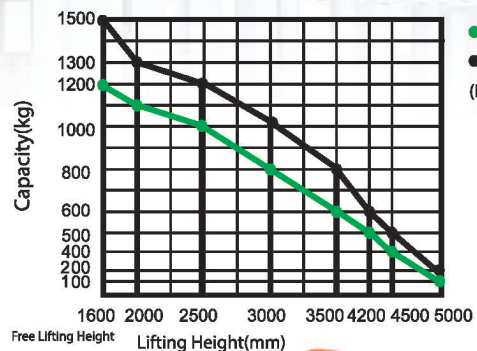
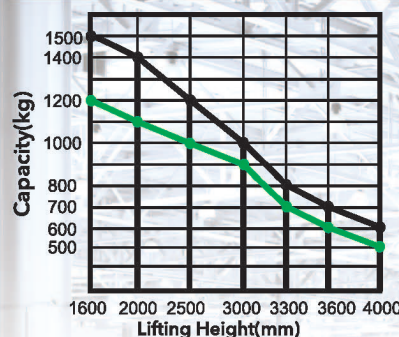

### Advantages

#### Configuration and Performance

- Fork tilt, double oil cylinder more smoothly.
- Electro-hydraulic integrated control, multi-function handle.
- Electronic power steering system, light and low noise.
- Two-way magnetic valve, three drop speed mode.
- AC Driving system, No carbon brush, maintenance free.
- Electromagnetic, regenerative braking system.
- Automatic lifting limit, proximity switch, long life.

#### Safety

- Curve automatic deceleration devices, more safe.
- Vehicle decelerates automatically at higher position.
- Stepless speed control system, safe and quiet.
- Controller with Multiple automatic protection.
- Emergency reversing device/Emergency brake switch.
- High position automatic reduction device.



AC | EPS

Down mode at 3 speeds

Standard fork tilt device

Type	Lift height (mm)	Mast type	Outside width between forks (mm)	Inside width between forks (mm)
CQDM12/15-810	1400/2000/2500/3000/3300/3600/4000	Standard 2-STAGE	200-755	0-555
CQDM12/15-810	2500/3700/3900/4200/4500/5000	FULL FREE 3-STAGE		

Max lift height more than 3300, tilting device can not accept.

Feature			
Model		CQDM12/15	CQDM12/15
Configuration No.		810	810
Type		Reach	Reach
Mast type		Standard 2-Stage	Full free 3-Stage
Load capacity	kg	1200/1500	1200/1500
Load center	mm	500	500
Wheel base	mm	1332	1332
Operating type		Stand On	Stand On
Wheels			
Wheels type		PU	PU
Wheel quantity Driving wheel/ Balance wheel/Bearing wheel		1/0/2	1/0/2
Dimension			
Reach distance	mm	0-425	0-425
Standard lift height	mm	1400/2000/2500/3000/3300/3600/4000	2500/3700/3900/4200/4500/5000
Max. extend height	mm	2280/2880/3380/3880/4180/4480/4880	3405/4605/4805/5105/5405/5905
Mast lowered height	mm	1490/1790/2040/2290/2440/2590/2790	1432/1870/1940/2040/2140/2359
Lowered fork height	mm	55	55
Fork size (length/width/thickness)	mm	1070/100/40	1070/100/40
Overall length	mm	2440/2896	2440/2896
Overall width	mm	1083	1083
Outside width between forks	mm	200-755	200-755
Tilt of fork (F/B)	mm	3/5	3/5
Min. Turning radius	mm	1596/2040	1596/2040
Min. Aisle width for pallets 800x1200		2620/3050	2620/3050
Min. Aisle width for pallets 1000x1200	km/h	2645/3075	2645/3075
Min. ground clearance	mm/s	60	60
Performance			
Travel speed, laden/unladen	%	5/5.5	5/5.5
Lift speed, laden/unladen		130/180	130/180
Lowering speed, laden/unladen	kW	100/180	100/180
Gradeability, laden/unladen	V	3/5	3/5
	Ah		
Electrical configuration			
Drive motor/Lift motor/Steering motor		AC1.5/DC3.0/DC0.15	AC1.5/DC3.0/DC0.15
Battery voltage		24	24
Battery capacity		280	280
Brake	kg	Electromagnetic/Regenerative	Electromagnetic/Regenerative
Controller	kg	ZAPI (Option CURTIS)	ZAPI (Option CURTIS)
Weight			
Battery weight		235	235
Service weight with battery		2185	2205

\* Details of specifications and equipment are based on information available at time of printing and may change without notice.

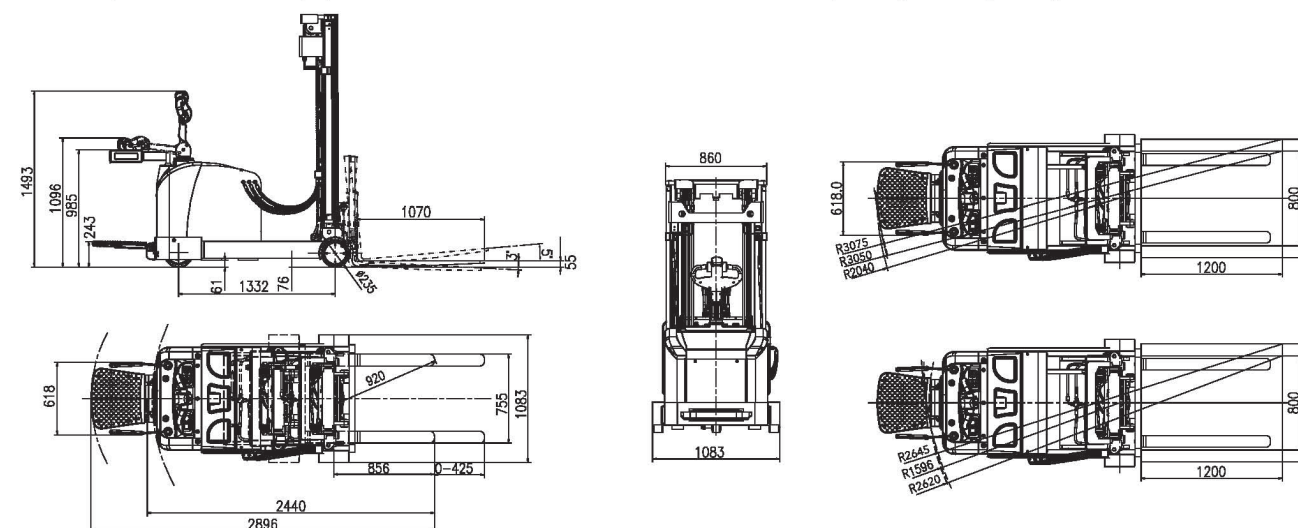

#### ANHUI HELI CO., LTD.

ADD: NO.668 Fangxing Street, Economical Development Zone, Hefei, P.R.China  
 TEL: (86 551)63639068 (America) 63639258 (Europe) 63639358 (Asia)  
 63662105 (Africa & Middle East) 63639530 (Key Accounts division)  
 63662105 (Wheel loader)  
 FAX: (86 551)63639966  
 WEBSITE: <http://www.heliforklift.net>  
 Email: [heli@helichina.net](mailto:heli@helichina.net)

AUTHORIZED DEALER